

EE 2240  
**Final Exam**  
Fall 2021

***Please read these comments and instructions before starting the exam:***

This is a **take-home** exam. You may use any resources you wish, with the exception of human consultants.

There are 6 problems, each worth a maximum of 25 points. Very little partial credit will be given, so please take your time and check your work.

***Clearly and completely*** define any variables you add to a problem for use in your solution. (Show them, along with your assumed reference direction or polarity if appropriate, on the circuit diagram.). Also, make a special effort to present your solutions in a neat and orderly manner. If a solution is difficult to follow, it's not worth as many points as one that is easy to follow.

**Your solutions are due on Tuesday, December 14, by 9:30AM.**

**No extensions will be granted.**

The solutions you submit must be done by hand. LTspice, MATLAB, and other tools may be used to check your work if you wish, but they may not be used to generate the solutions you submit for grading.

***PLEASE* submit your solutions as a single PDF file.**

Name \_\_\_\_\_  
By writing or printing my name in the space above, I hereby affirm that I have neither given nor received assistance in preparing my solution for this problem.

1. Is the independent voltage source *absorbing* or *delivering* power? How much? Show work to justify your answers.

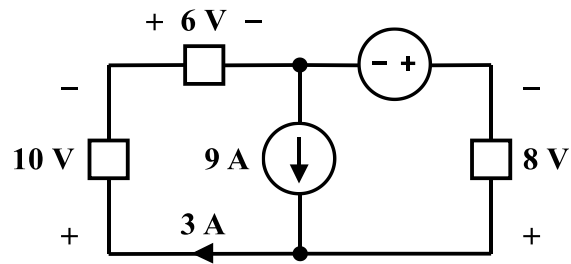

Name \_\_\_\_\_  
By writing or printing my name in the space above, I hereby affirm that I have neither given nor received assistance in preparing my solution for this problem.

2. Find the numerical value, including sign, of  $I_o$ .

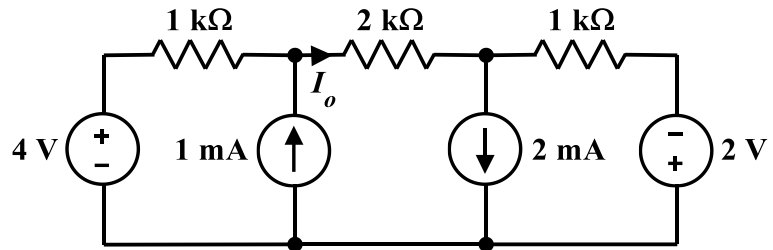

Name \_\_\_\_\_  
By writing or printing my name in the space above, I hereby affirm that I have neither given nor received assistance in preparing my solution for this problem.

3. The operational amplifier is ideal. Determine the numerical value, including sign, of  $V_o$ .

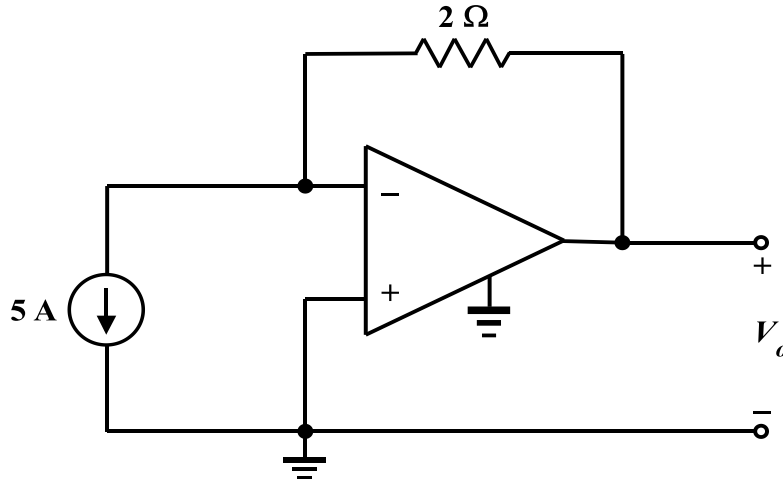

Name \_\_\_\_\_  
By writing or printing my name in the space above, I hereby affirm that I have neither given nor received assistance in preparing my solution for this problem.

4. Find the numerical value, including sign, of  $V_o$ .

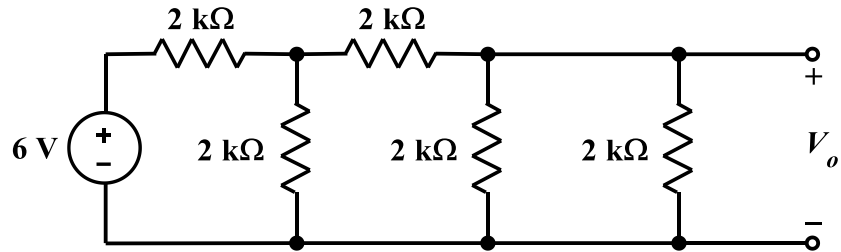

Name \_\_\_\_\_  
By writing or printing my name in the space above, I hereby affirm that I have neither given nor received assistance in preparing my solution for this problem.

5. The switch has been in position  $a$  for a long time, and is suddenly thrown to position  $b$  at  $t = 0$ . Find  $v_o(t)$  for  $t \geq 0$ .

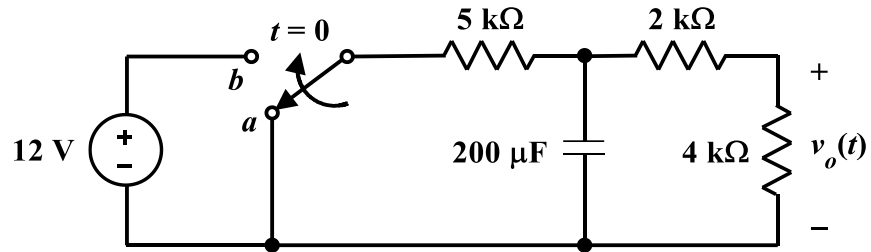

Name \_\_\_\_\_  
By writing or printing my name in the space above, I hereby affirm that I have neither given nor received assistance in preparing my solution for this problem.

6. The circuit shown below is an underdamped system, and the current through the inductor has the form  $i_L(t) = e^{\alpha t} (K_1 \sin \omega t + K_2 \cos \omega t)$  A for  $t \geq 0$ .

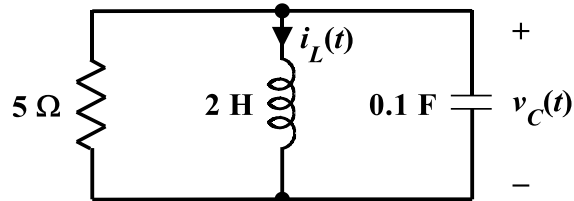

- a. Determine the numerical values, including signs, of  $\alpha$  and  $\omega$ .
- b. If the initial conditions are  $i_L(0) = 1 \text{ A}$  and  $v_C(0) = 12 \text{ V}$ , determine the numerical values, including signs, of  $K_1$  and  $K_2$ .
- c. Using the numbers determined above, write out the complete expression for  $i_L(t)$ .